

ENGLISH

PUMP INSTRUCTION MANUAL

**Valid for the series AX, CRP, FMS, FP, ICP, IFF, MFF, IRP,
KNM, MCP, MFP, MSP, MWP, NMS, NP, PHP, PRP, IPP,
FPP, SFP, VPC and VDK**

ENG

Thank you for selecting a PACKO pump. Please **read this manual carefully** and observe the information contained with respect to:

- **Safety,**
- **Working reliability,**
- **Storage,**
- **Installation,**
- **Start up,**
- **Maintenance,**
- **Repair.**

This manual has to be available at the location where the pump is used and available for everyone who has to work with, or on the pump. If there are unclear points in this manual, please contact PACKO for further information.

Contents

1. General information	69	5. Operation of the pump	86
1.1. Manufacturer and country of origin	69	5.1. Operation with closed valves, minimum flows	86
1.2. Copyright	69	5.2. The phenomenon of water hammer	87
1.3. Product information	69	5.3. Operation of pumps with a frequency converter	87
1.4. Model designation	70	5.4. Pumps that have to start and stop often	87
1.5. Noise level	71	5.5. Temporary decommissioning	88
2. Safety	72	5.6. Permanently decommissioning	88
2.1. Declaration	72	5.7. Directives in case of failure	88
2.2. Designated use	72	5.8. Clearing a blockage	88
2.3. Warnings and safety notes	73	6. Maintenance, spare parts and cleaning	89
2.4. Pumps resorting under the 2014/34/EC directive (ATEX)	76	6.1. Maintenance of the motor	89
3. Transport and temporary storage	78	6.2. Mechanical seal	89
3.1. Transport	78	6.3. Spare parts	89
3.2. Temporary storage	78	6.4. Cleaning	90
4. Installation and operation	79	7. Problem solving	91
4.1. Preliminary	79	8. Assembly and disassembly	92
4.2. Lifting the pump	79		
4.3. Location of the pump	79		
4.4. Electrical connection of the motor	80		
4.5. The pipe work installation	81		
4.6. The pipe work for self priming and air-handling pumps	83		
4.7. Pumps with quench	84		
4.8. Putting into operation	85		
4.9. Starting the pump	85		

1. General information

1.1. Manufacturer and country of origin

PACKO INOX LTD
Cardijnlaan 10 – Industriepark Heernisse
B-8600 Diksmuide
Belgium
Phone: + 32 51 51 92 80
Fax: + 32 51 51 92 99
E-mail: pumps@packo.com

1.2. Copyright

This manual has been prepared to ensure correct and safe installation, use and maintenance of the pump in accordance with the EC directives “Machinery”. It is originally written in Dutch, English, French and German by the manufacturer. All other languages are translations of the original manual.

PACKO INOX LTD has the copyright on this document. This manual can be copied completely for the manual of the machine or installation in which the pump is used and can be used for the instruction of the personnel who have to work

with or on the pump. Any other publication, copying or use is prohibited.

This manual has been prepared carefully. However it does not contain all the possible accidents that could happen during installation, operation and maintenance of the pump. It is important that the pump is not used for any purpose other than the specified application given when ordering the pump and for those that the pump was built. This might cause material damage and injuries.

1.3. Product information

The FP, NP, ICP, MCP, MWP, MFP, PHP, FPP and IPP series are single stage centrifugal pumps, close coupled to the motor or onto a pedestal. The inlet of the pump is located on the central axial; the outlet is tangential or radial. These pumps are used for circulating pure and slightly contaminated liquids. The FP and MFP series meet the hygiene requirements imposed by the food industry and are suitable for circulating food products. The PHP series have a high-grade finish, which is agreed when the pump is ordered.

- Pumps with a suffix IL in their name are in-line pumps and the direction of the liquid flow is indicated with an arrow.
- The series IM are vertical cantilever pumps. These are designed to be set vertically with

the pump immersed in the suction reservoir. The motor has to stand above the maximum liquid level.

- The MSP series are self-priming centrifugal pumps.
- The VPC, VDK, MFF and IFF series are suitable for the circulation of liquids with a small percentage of solid substances. The maximum size of these substances is 1 cm for the MFF and IFF types and half of the diameter of the inlet for the VDK and VPCP types. These solid substances can be damaged in pumping.
- The AX series are axial pumps suitable for the circulation of big flows with a low head.

- The FMS and NMS series are multi-stage pumps designed to handle small flows at a bigger head.
- The CRP, PRP and IRP types are centrifugal pumps designed especially for pumping liquids with a small quantity of air (e.g. CIP return applications).

- The SFP series are high shear pumps for emulsifying liquids and dispersing powders in liquids.

Please refer to the technical leaflets for more details.

1.4. Model designation

The model designation is given on the order confirmation, CE declaration, invoice and also on the nameplate:

PACKO INOX LTD DIKSMUIDE BELGIUM		Packo	
TYPE:			
Mat. code:			
Year:	S/N:		kg
Q:	m ³ /h:	H:	m
DO NOT RUN PUMP DRY			

Example:

Type: FP2/32-125/302

- FP2: type of pump
- 32: nominal outlet diameter
- 125: nominal impeller diameter, size of pump
- 30: motor power in kW multiplied by ten (30 = 3 kW)
- 2: Number of poles of the motor

Mat. Code: (O-140) D10S33KEW

- O: impeller type (= open, C = closed, SO = semi-open closed backside, VO = vortex, A = axial, OI = open with inducer, CI = closed with inducer), OP: open polished impeller.
- 140: actual impeller diameter;

- D: type of connections (D = DIN 11851, B = BSP male, C= BSP female, E = EN1092-1/02, F = EN1092-1/01, R = RJT, S = SMS, I = IDF, T = Tri-Clamp, ISO2852, M = Triclamp ASME BPE, O = Tri-clamp ISO 1127, N = ANSI flanges, V = DIN 11864-1, A = DIN 11864-2, W = APV flanges, P = Danish standard)

- 10: motor frame divided by ten (rounded up);
- S: seal configuration (S = standard single seal, A = sterile balanced seal, B = sterile balanced seal with quench, C = double seal with sterile balanced seal on product side, D = double seal pressureless, P = double seal with pressurized barrier, Q = quench, R = quench reservoir, I = double seal with internal circulation of flushing liquid, J = sterile double seal with internal circulation of flushing liquid, K = double mechanical seal with pressurized barrier and integrated flushing liquid circulation, O = pusher seal, N = pusher seal + quench)
- 33: diameter of the primary mechanical seal
- K: materials of the mechanical seal (K = carbon/siliconcarbide, S = siliconcarbide/siliconcarbide, C = carbon/ceramics, J = Silicon impregnated carbon/ siliconcarbide);
- E: material of the rubber parts (E = EPDM, V = FKM, M = FEP coated viton, S = silicone)
- Gasket for pump casing and EPDM in the mechanical seal, K = perfluor elastomer; Q = silicon gasket for pump casing and perfluor elastomer in the mechanical seal, P = perbunan)

- W: options (W = only motor and pump, B = motor, pump and motor base with adjustable feet, S = motor, pump, motor base with adjustable feet and shroud, F = Frame without adjustable feet, T = Trolley, U = Trolley + shroud, G = Portable, M = Base plate with adjustable legs with rubber pad, N = Shroud and base plate with adjustable legs with rubber pad, H = Stainless steel pedestal hydraulic motor, P = On cast iron pedestal, Q = On cast

iron pedestal with base and motor, R = Cast iron pedestal with base, motor and shroud).

An X in the code indicates a special execution.

Also shown on the nameplate are the year and week of production, the weight and the duty point of the pump, together with the serial number which should be quoted when ordering spare parts.

1.5. Noise level

The noise generated by a pump depends on different factors. Most important are: power, speed and brand name of the motor, whether there is cavitation or not, operating point of the pump, and handling of small quantities of air. In certain installations and duty points the noise level mentioned below can be exceeded. To reduce the noise and the vibrations, no other parts of

the machine can vibrate simultaneously with the pump. That's why it is best to let the pump rest directly on the concrete, or to assemble shock absorbers between the pump and the machine frame. The maximum sound pressure level for pumps with two-pole motors in normal circumstances on 50 Hz is:

Motor power	P < 11kW	11kW < P < 22kW	22kW < P < 45kW	45kW < P < 250kW
FP – NP – ICP – PHP – MCP – MFP – MWP – FMS – NMS – VDK – VPC – FPP – IPP	80 dB(A)	88 dB(A)	90 dB(A)	94 dB(A)
CRP – IRP – PRP – IFF – MFF – MSP – AX	85 dB(A)	88 dB(A)		

For other speeds the above mentioned values have to be corrected as follows:

Two-pole 60Hz	+4 dB(A)
Four-pole 50Hz	-10 dB(A)
Four-pole 60Hz	-8 dB(A)
Six-pole 50Hz	-15 dB(A)
Six-pole 60Hz	-13 dB(A)

2. Safety

2.1. Declaration

Within the meaning of the EC-directive “Machinery”:

A pump never functions independently. It is intended to be incorporated into machinery. It should only be put into service if the machinery

has been declared to conform to the provisions of the EC-directive “Machinery”. (2006/42/EC).

PACKO INOX LTD reserves the right to carry out technical modifications that might be necessary to improve the products that are not mentioned in this manual.

2.2. Designated use

The pump is intended to be built into a piping installation and to increase the pressure and velocity of the liquid coming into the inlet via the suction pipe and discharge it to the discharge pipe via the outlet of the pump. Therefore the motor must be supplied by an electrical power supply according to the nameplate of the motor. The load of the motor depends on the flow of the pump. The motor was selected for the duty point stated on the nameplate of the pump. If the pump must operate at another duty point, check if the installed motor is suited for these circumstances.

Every pump is specifically built for a particular application. The pump parts, materials, seals and motor power have been chosen according to:

- the liquid (composition, physical and chemical properties),
- the required pump capacity (pressure, minimum and maximum flow),
- the mains voltage available,
- Operating circumstances (system pressure, presence of air bubbles or solids, place of installation).

The viscosity of the circulated liquid must be between 0.35 cP and 1000 cP (maximum 250 cP for FMS and NMS pumps). The liquid cannot contain air (except for CRP, IRP, PRP, and MSP pumps) or solids (except for IFF, MFF, VPC and VDK pumps). The system pressure and the temperature of the circulated liquid must not exceed the temperature mentioned in chapter 2.3. The minimum flow in continuous duty is 1 m³/h per kW installed motor power. For FMS and NMS pumps the minimum flow is 0.5 m³/h irrespective of the installed motor power. The ambient temperature must be between 0°C and 40°C. The pump cannot be installed higher than 1000 m above sea level.

For pumps supplied under guideline 2014/34/EC (Atex), all statements on the declaration of conformity are part of the designated use.

Every other use or an utilization going beyond the specifications is considered contrary to its designated use and excludes liability by the manufacturer PACKO. All safety notes stated in 2.3 form an integral part of the designated use.

2.3. Warnings and safety notes



The pump may never be used independently. It is intended to be incorporated into machinery.

There must always be piping connected to the inlet and the outlet.



The pressure in the pipe work should not exceed the following values:

Pump type	Maximum pressure of pumps with open impeller	Maximum pressure of pumps with closed impeller
FP4100 – FP4600	Max 0.7 bar on the inlet	
FP, NP and IFF 63, 66 and 68	Max 5 bar on the inlet	
VPC, VDK and AX series	Max 2 bar on the inlet	Max 4 bar on the outlet
MSP series	Max 2 bar on the inlet	
FMS, NMS, FP1 and ICP1 series	Max 6 bar on the inlet	
FPP, IPP	Max 40 bar on the inlet	
All other pump series Types 125 Types 160 and 185 Types 200 Types 250 Types 315	Max 13 bar on the inlet Max 10 bar on the inlet Max 4 bar on the inlet Max 3 bar on the inlet	Max 10 bar on the outlet Max 12 bar on the outlet Max 15 bar on the outlet Max 8 bar on the outlet

The values mentioned above are the maximum allowed pressures for pump casing and backplate. The maximum allowed pressure for the complete pump depends on the type of the mechanical seal. The values mentioned above are only valid with a sterile balanced mechanical seal. (seal configurations A, B, C or H). It is advisable to make arrangements that restrict the pressure on the outlet of the pump.

The **maximum allowed speed** of the pump is limited through:

- The maximum pressure in the pipe work (see above)
- The motor power. When the pump is turning faster, it needs more power.
- The maximum speed can never be higher than 3600 revolutions per minute

When the motor turns very slowly, **its own cooling can be affected**. The **minimum speed** for pumps with a two-, four- or six-pole motor is 15 Hz and 25 Hz for pumps with a 8-pole motor.



The maximum allowed temperature of the pumped liquid depends on the seals in the pump and the vapor pressure of the pumped liquid. For more specific details, we advise you to contact PACKO. In general you can choose the smallest of the following limitative values:

- Maximum temperature for the rubber** (depending on the liquid): **90°C for perbutan, 125°C for EPDM, 200°C for Viton, FEP and Kalrez, 110°C for silicone.**
- Pumps with a simple mechanical seal: **15°C lower than the boiling point of the pumped liquid** at the pressure on the inlet of the pump. Pumps with a flushed seal (quench or double seal) support a higher temperature if the sliding surfaces of the mechanical seal are sufficiently cooled down.
- To guarantee good lubrication of the motor bearings, special motors have to be used for the handling of liquids with a temperature higher than 150°C.**

D. The maximum temperature for pumps with a mechanical seal with carbon is 120°C.



When the pump is used for handling liquids with a temperature lower than 10°C or higher than 40 °C, the pump and piping bringing the liquid to and away from the pump should be protected against human contact, in this way the operators or other persons cannot burn themselves. The cooling of the motor must not be affected by this protection.



When handling hazardous liquids, be sure that the liquid does not affect the seals and that the connections on inlet and outlet of the pump are made leakage free. When handling a toxic or odorant liquid, **ensure working area is well ventilated.** Do not allow dangerous liquids to flow into the local sewage system or river systems when the pump has a leak. Do not drain hazardous liquids such as chemical solutions directly onto the ground. Instead, drain such liquids into a suitable container. When handling toxic or hazardous liquids, contact PACKO to check whether the used sealing materials are suitable for the liquid.

Never stand on a pump! The pump was not designed and manufactured for this. The pump could be damaged, and injury may occur.



When assembling, disassembling and during installation and maintenance, all engineers must wear **safety gloves, a helmet and protective shoes.** In addition, when handling wetted parts, always wear **protective goggles or a mask.** Do not smoke or eat during these operations. Hazardous liquids may be on the pump parts. **Damaged or deteriorated tools** are very dangerous and can cause serious injuries.



Make sure the **rope or chain used for lifting the pump has sufficient strength** in relation to the weight of the pump (see nameplate) and is **not damaged.** **It is strictly prohibited to stand underneath a lifted or suspended pump.** A falling pump can lead to death or serious injury. Only lift a pump as described in this manual. Make sure your fingers are not caught between the pump and rope or chain.



The motor should be connected to the power supply in accordance with EN 60204 and local stan-

dards. **An electric control panel and emergency stop has to be foreseen according to 2006/42/EC.**

Run the pump at the **specified power supply voltage on the nameplate of the motor only.** Otherwise, motor damage or electric shock may result.

When the thermal protection of the motor is activated, switch off the main switch. **Only switch it on again when the reason for this interruption has been found and repaired.**



When the electrical power has failed, **it may not be possible that the pump restarts automatically when the electrical power supply comes up again.** When restarting manually, check and make sure that there is no one near the pump when switching on the power supply.

Only vertical cantilever pumps (suffix IM in the pump code) are designed to be used under water. Even with these pumps, the motor has to stand at least 10 cm above maximum liquid level. These pumps are always installed vertically. All other pumps can **never be used under water.**

Provisions should be taken so that, in case of a leakage of the installation, the level of the liquid cannot rise to the level of the motor.

Only the MSP series are self-priming. For the self-priming pumps, **prime the pump casing by** pre filling before starting the pump and every time when emptying the pump. Prime all other not self-priming pumps by **completely** flooding the inlet before starting the pump.



Repairs to the pump are only allowed when the pump is not active and the power is switched off. The pump should be pressure

less, empty and at room temperature before opening it or taking it out of the installation. The valves on the inlet and outlet of the pump must be closed. Pumps circulating liquids that are health hazardous must first be decontaminated. Make special provisions so that no other operator mistakenly turns on the power supply while someone is working on the pump. In a noisy or poor visibility environment, display a sign near the power supply switch to notify that someone is working on the pump.



Certain types of pumps comply with european regulation 1935/2004 EC (materials and articles intended to come into contact with food). However, this compliance is only valid for the interior of the pump. The end-user has to make sure no particles or droplets of liquid can fall from the outside of the pump or from the motor into the food.

It is forbidden to interchange parts of a pump with another, even if they are original PACKO spare-parts. The only exception is the repair with original PACKO spare-parts with the same characteristics. When ordering original spare-parts, the data on the nameplate (serial number and pump type) have to be mentioned every time. It is forbidden to change the impeller to one with another diameter or to install a motor of another speed or power without written permission of PACKO.

When using the pump at another duty point or for another liquid not mentioned when you ordered the pump, be sure the motor power is sufficient. In case of doubt, contact PACKO.

PACKO pumps are manufactured to a **high quality standard and working reliability.** Yet, if they are not operated in accordance with their intended purpose or handled incorrectly by untrained personnel or not in accordance with this manual, **they may cause risks for personnel or the environment.**

The user is asked to check as part of his security program **what effects a failure** of the pump might have on the environment and what **additional safety measures** to prevent personal injury have to be taken.

The operation of the pump in unsafe conditions is prohibited.

PACKO pumps must be installed, operated and maintained by qualified personnel. Everyone involved in installation, assembly, disassembly, operation and maintenance of a PACKO pump must have **read and understood this manual** and in particular the **safety notes.**

Apart from the safety notes mentioned in this manual, the general safety regulations and the national regulations for the prevention of accidents, as well as any internal labour, operating and safety regulations supplied by the owner, are to be observed. (E.g. 89/655/ EEC: use of implements)

Any modification to the pump that may have an influence on its safety or reliability is forbidden.

If in doubt please contact PACKO.

2.4. Pumps resorting under the 2014/34/EC directive (ATEX)



PACKO pumps according to 2014/34/EC are designed and manufactured to reduce as much as possible the risk of explosion. Nevertheless, the degree of explosion safety of the pump in the installation can only be assured by the joint precautionary measures of the pump constructor PACKO and the user.

The table below shows an overview of the risks by pump type and whether the pumped liquid is inflammable, as well as the preventive measures available.

The cells in the table where the text is *italicized* indicate the absence of the risk.

The cells in the table where the text is in **bold** indicate risks prevented by modifications to the pump by the constructor PACKO. The modifications can only prevent the risk through proper use by the end-user.

The cells in the table where the text is underlined indicate risks that the user must avoid.

Pump	Liquid	Risk	Dry-running mechanical seal (Friction faces overheated are source of ignition)	Operating with closed valve (The outside wall temperature can be above the temperature class)	Leak (igniting liquid can be release into atmosphere)
Flooded suction	Non-ignitable liquid		Flushed seal or temperature control of seal or flow monitor by user		<i>No danger</i>
	Ignitable liquid				Flushed seal or preventive maintenance by the user
Air handling or self-priming	Non-combustible liquid		Flushed seal	<u>Flow monitoring by the user</u>	<i>No danger</i>

Normal-priming pumps are pumps from the series FP, NP, ICP, PHP, MCP, MFP, MWP, FPP, IPP, SFP, FMS and NMS.

Air-handling pumps are pumps from the series CRP, IRP, and PRP.

Self-priming pumps are pumps from the series MSP.

The flashpoint of a liquid is the lowest temperature at which sufficient vapour is created above a liquid so that it can ignite when mixed with air.

A combustible liquid is not ignitable as long as the temperature is lower than the liquid's flashpoint. It is important to note that specific components (primarily the mechanical seal and the motor) of the pump can be warmer than the temperature of the liquid being pumped. When a mechanical seal runs dry, it becomes very hot (up to 400°C +). As a result, a liquid with a flashpoint that is much higher than the temperature at which it is being pumped must nevertheless be considered as potentially inflammable when assessing the risk of dry running of the mechanical seal and the risk of leaks.

Pumps with flushed mechanical seals

A continuous flow of the flushing medium must be assured. When the flush is interrupted, the motor must be stopped immediately. Otherwise the mechanical seal could run dry and cause dangerously high temperatures. If a quench reservoir is being used, the level of the flushing medium in the reservoir must be monitored by an ATEX-approved level monitor. If the level gets too high, the seal is leaking and must be replaced. If the level is too low, then flushing is not assured and the seal could run dry. The reservoir must be filled up. The temperature of the flushing medium in the reservoir must be monitored by an ATEX-approved temperature control. The temperature of the liquid in the quench reservoir must be kept under 75°C; if necessary, provide external cooling. It is the responsibility of the end-user to select a suitable flushing medium. The flushing medium may not damage the seals and must not form an explosive mixture when mixed with the pumped medium.

The pump must never be run against a closed valve on the suction and should not be run against a closed valve on the discharge for longer than 1 minute. If necessary, an ATEX-approved flow sensor must be installed to guarantee that that will not happen.

Pumps with single mechanical seals

The flow must be monitored (e.g. with an ATEX-approved flow-sensor at the inlet of the pump). If no flow is detected, the motor must be stopped immediately.

Leakage of a combustible liquid is a serious safety risk. The end-user must assess the consequences of a leak and adjust the frequency that the mechanical seal is checked accordingly. When a leak is found, the pump must be stopped immediately and the mechanical seal replaced. Possible causes for the mechanical seals to fail include: chemical or thermal damage to the elastomers by the pumped product or cleaning substance, suspended particles in the medium, crystallization, hardening

or sticking, dry running and cavitation. The mechanical seal must be replaced preventively at least once every 3,000 operating hours.

Self-priming and air-handling pumps

Because of the working principle of self priming and air-handling pumps, there are periods where air and pumped liquid are mixed together inside the pump casing. During that time, the mechanical seal runs almost dry. For this reason, self priming and air-handling pumps according to 2014/34/EC must always be equipped by a flushed seal. Self priming and air-handling pumps are forbidden for combustible liquid circulation. Because of this air and combustible liquid mixture, a zone 0 is created inside the pump.



Pumps circulating a combustible liquid, must always be completely filled up and be kept filled before

start up, during operation and after shut down. When air comes into the pump, an air and combustible mixture is created. This is an extremely dangerous situation (zone 0).

The pumps according to 2014/34/EC can only pump clean liquid without particules.

Exe motors may not be fed by a frequency converter. Eexd(e) motors can be used with a frequency converter, but only if the PTC's are connected (the purpose is to shut down the motor before overheating) and if the motor is derated. Derating means a motor fed by a frequency converter cannot be loaded until nominal power (for cases above 50Hz) or its nominal torque (for cases below 50Hz). The derating value depends on the frequency range at which the motor is used. When the range is known with the order, PACKO can provide a second name plate with derated power and torque.

ATEX motors may not be painted over. If the paint layer becomes too thick, static electricity can build up; it also acts as an additional insulation layer, with the result that the temperature class can no longer be guaranteed.



When a **new motor** has to be installed on the pump, you have to make sure the maximum axial

movement of the shaft under a 10.000N axial load is less than 0.3 mm. This maximum movement must be guaranteed in cold and operational warm condition. The fixation has to be done in the bearing on pump side so the thermal elongation of the shaft goes in the direction of the fan.

The reliability of control equipment (e.g. mass flow sensor or liquid level sensor in a quench reservoir) should be checked regularly.

The pump must be protected against all damages from external sources.

PACKO pumps are classified under Group II, Categories 2 and 3. According to directive 99/92/EC (ATEX 137), it is the responsibility of the user to classify the zone and to choose the corresponding protective and temperature class of the motor.

The recommendations stated on the declaration of conformity must be followed precisely.

3. Transport and temporary storage

3.1. Transport

The pumps are packed in our dispatch department so that they will be free from any transport damage, except in case of improper treatment. The pump is to be transported in the original

packaging to the installation, where it is to be unpacked. If the packaging is damaged, the supplier or PACKO is to be notified of any damage that may have occurred before unpacking.

3.2. Temporary storage

It is recommended to store the pump in dry (air humidity less than 90 %) and dust free surroundings, free from impacts, vibrations or temperature extremes. Motor windings and metal parts may be affected by condensation. In that case, the warranty will be invalid. When the pump is stored

for a long time, the impeller must be turned by hand every two months. This will prevent the sealing faces from sticking together and the motor bearings from being damaged.

4. Installation and operation

4.1. Preliminary

In order to check if the pump you received is exactly the pump you need and ordered, check during unpacking if the model, description, flow

and head on the nameplate of the pump are the same as on your order. Check voltage, frequency and power on the nameplate of the motor.

4.2. Lifting the pump

For pumps that cannot be lifted by hand, a sling is tied around the pump during the packaging in our dispatching department. This sling can be used to lift the pump out of the packaging. Pumps without shrouds can also be lifted on the eyebolt of the motor. If the pump casing is provided with a lifting eye, the pump must be lifted on both the lifting eye of the motor and the pump casing. It is best to put the pump onto a trolley after lifting it out of the packaging to take it to the place where the pump must be installed.

When the sling has been removed, the pump may only be lifted on the eyebolt of the motor.

If the pump casing is provided with a lifting eye, the pump must be lifted on both the lifting eye of the motor and the pump casing. For pumps with a shroud, remove the shroud and replace after connecting the motor according to the procedure described in 4.4. Never put back a removed sling yourself! The sling can only be used once, after which it should be destroyed.



Never go underneath a suspended pump or a pump being lifted.

Put down the pump carefully in order not to damage the internal parts.

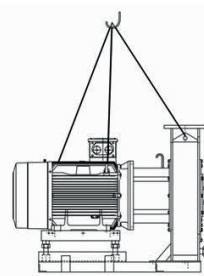
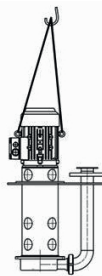
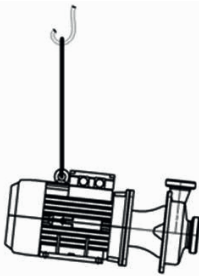

4.3. Location of the pump

The pump should be located in your installation so that it is easily accessible for maintenance. You should make sure that the pump is surrounded by a maximum of dry space and the motor can circulate enough cooling air. At the back of the motor or motor shroud, there must be at least 10 cm free area. The maximum ambient temperature is 40°C. The pump may not be installed at altitudes more than 1000 Mt above sea level. Standard pumps should not be

installed in an explosive environment or close to explosive materials.

As an option, the pump can be supplied according to 2014/34/EC (ATEX).

Install the pump directly onto a level floor or on the frame of the installation. If the floor is not level, this can be corrected by adjusting the adjustable feet or by using blotting-pads.

The pump should be installed as close as possible to the storage tank and as low as possible. The NPSHa must be at least 0.5 Mt higher than the NPSHr of the pump in the desired operating point. Only in this way will cavitation be avoided. The NPSHa (Net Positive Suction Head available) is the total absolute pressure on the inlet of the pump (static pressure and dynamic pressure) reduced by the vapor pressure of the liquid. This is the same as the sum of the absolute pressure present upon the liquid in the storage tank, and the height of the liquid column above the inlet of the pump, reduced by the total hydraulic losses of the piping between the storage tank and the inlet of the pump and by the vapor pressure of the liquid. The NPSHr (Net Positive Suction Head required) can be found in our technical leaflets. If you are not sure the suction conditions of the pump in your installation are OK, please contact PACKO.

In order to get good de-aeration, the pump should be installed horizontally (motor shaft horizontal) with the outlet vertical on top, or the outlet horizontal on top towards the right, seen from the motor to the pump. In other positions, make sure you have a good de-aeration.

As an option, pump casings with de-aeration ports are available. When the pump is installed vertically with the motor on top, the motor must be protected against falling water. Never install the pump vertically with the motor below. A MSP, CRP, PRP or IRP pump is always installed horizontally and with the outlet of the pump on top. Fix the pump on the base of the motor or on the adjustable feet.

The pumps in the series NPIM, ICP2IM and ICP3IM must be mounted so that the bottom of the motor stands 10cm above the top of the vessel (IML and IMXL). This also applies to the externally mounted (IMO) models. This is to ensure that the motor can never be submerged.

4.4. Electrical connection of the motor

The electrical connection of the motor should only be carried out when the power supply is switched off. This should be done by qualified personnel and according to EN 60204 and local national rules and standards. Special attention should be paid to good earthing which must conform to your local national rules. Check on the nameplate of the motor if it is suited to operate on the available voltage and frequency.

Select the protection system and the feed cables according to the details on the identification plate of the motor. The drop in voltage during the starting phase must be less than 3 %.

Tighten the nuts of the terminals, connectors and supply cables to the torque indicated below (Nm):

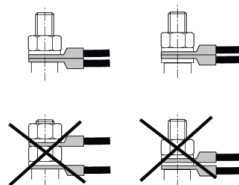

Terminal	M4	M5	M6	M8	M10	M12	M16
Steel	2	3.2	5	10	20	35	65
Brass	1	2	3	6	12	20	50

Do not place either washers or nuts between the motor connectors and the supply cable connectors.

Ensure that the cable gland is dust and damp proof: the cable gland must correspond to the diameter of cable used. Bring the cables into the terminal box with a radius that prevents water from penetrating via the cable gland. (The cable must leave the motor downwards.)

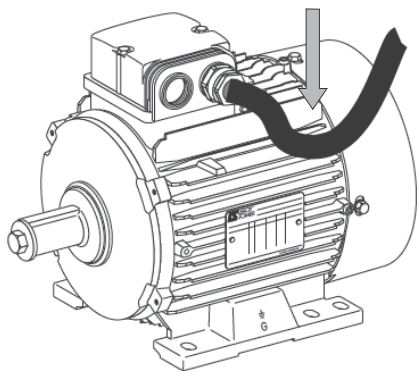

Connect according to the coupling information on the identification plate and the diagram in the terminal box. Do not connect the motor if you do not understand the wiring diagram. Please contact PACKO in that case. Never check the direction of rotation of the pump with an opened terminal box of the motor. The installer is responsible for following the rules on electrical compatibility

applicable in the country where the pump will be used.

Comply with the voltage and frequency indicated on the nameplate. (Do not deviate by more than 5 % from the voltage indicated or by more than 1 % from the frequency.)

For pumps with a motor power of more than 75 kW, special starting provisions must be taken (star-delta starter, soft starter or starting with frequency converter).

As an option, motors with built-in PTC thermal protection are available. When the motor senses danger of heat, the resistance of this PTC (which comes out in the terminal box of the motor with two threads) increases strongly. The PTC has to be connected to a PTC relay or frequency converter that switches off the motor when the motor becomes too hot.

The installation of a thermal protective device is always required.

ENG

4.5. The pipe work installation

The inlet and outlet of the pump are closed with plastic plugs for packaging. Remove those plugs before connecting the pump to the pipe work.

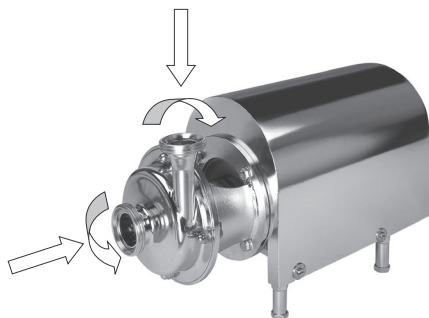

The pipe work should be made frost-proof. Clean the pipe work before connecting to the pump so that no foreign particle can come into the pump during starting up. The pipe work must be carried out according to good manufacturing practice and connected to the pump without mechanical forces. The suction and discharge pipe must

be supported so that their weight must not be borne by the pump. Provisions for the expansion and contraction of the pipes due to warming up and cooling down must be taken (e.g. placing compensators).

The maximum allowable shear load on the pump connections is the pipe dimension of the connection in mm multiplied by 8 Newtons. The maximum allowable bending moment is the pipe dimension of the connection in mm multiplied by 1Nm. For the series FP, NP, CRP and IRP 63, 66 and 68 the values mentioned above must be halved.

In the suction pipe a full bore valve must be installed, in the discharge pipe a regulating valve should be installed to make it possible to turn off the system completely when the pump must be removed for maintenance or repair. Also provide a drain valve on the inlet of the pump. Earth the pipe work according to the local directives.

The diameter of the suction pipe should be at least as great as the inlet diameter of the pump. In order to prevent cavitation, the suction pipe should have a hydraulic resistance that is as low as possible. This means it should be as short as possible, contain no filters and the minimum number of bends possible. Bends should have a large radius. When there is a bend at a distance less than 0.5 m or 8 times the suction diameter before the pump, the pump's efficiency can be influenced.

All valves in the suction pipe should be full bore. When there is a possibility the storage tank contains particles, the connection of the suction pipe on the tank must be at least 1.5 times the diameter of the suction pipe above the bottom of the tank. It is recommended to also put a screen in those situations. In no way should the liquid coming into the pump contain particles of more than 0.25 mm. (Except for VPC, VDK, MFF, MWP and IFF pumps, which are suited to circulate food particles.) When the liquid may contain particles, this must be mentioned when ordering the pump in order to select the right mechanical seal.

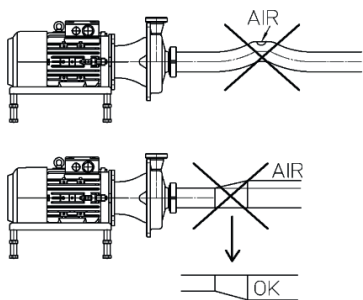

To prevent air traps, the suction pipe must contain no bridges (a part of a pipe that has both ends lower than the middle) and should have an ascending gradient of 1 % toward the pump. Pipe reducers should be of an eccentric type and installed so that no air can be trapped (not for MSP, CRP, PRP and IRP). Install the suction pipe in a way that the liquid flows automatically into the pump. (Not for self-priming pumps MSP)

If the level of the liquid in the suction vessel is less than 8 times the diameter of the suction pipe above the inlet of the pump, an anti-vortex device has to be installed in the suction pipe to prevent air from being drawn into the pump.

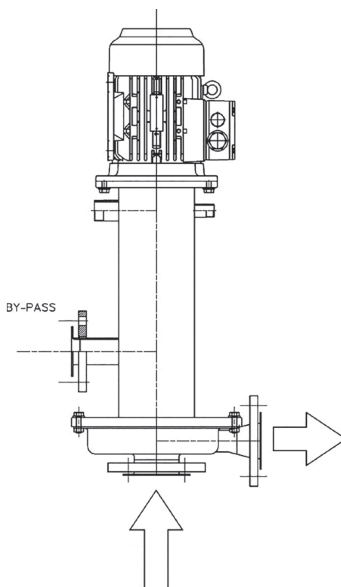

For pumps with a drain valve on the pump casing, this drain must be connected to a piping that's pressureless in order to guarantee draining of the pump. If the drain valve is operated electrically or pneumatically, the operation of the drain valve must be integrated in the control circuit of the installation or machine in which the pump is integrated.

The length and diameter of the discharge pipe will determine the operating point of the pump. The pump selection is based on the information given together with the inquiry. It is therefore important that the discharge pipe work installation is carried out according to the same plans as those used for the pump selection. It is recommended to install a pressure gauge directly on the outlet of the pump.

For the externally mounted pumps in the series NPIMO, ICPIMO and MCPIMO there is a by pass

connection in the bracket. This must be connected directly to the suction vessel with no rise in the pipework and no valves should be fitted. At the top of the column there are two nipples,

at least one of these must be left open as an emergency overflow to prevent liquid coming into contact with the motor.

4.6. The pipe work for self priming and air-handling pumps

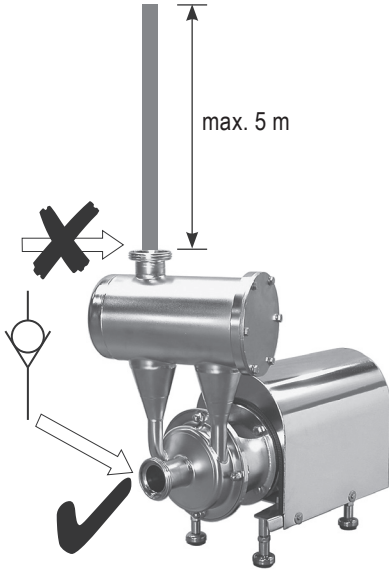

A good operation for self-priming pumps (types MSP) and air handling pumps (types CRP, PRP and IRP) depends on the design of the discharge pipe. It is necessary that the air on the outlet of the pump can evacuate freely via the discharge pipe to the discharge vessel or the environment. When bridges (a part of a pipe that has both ends lower than the middle) occur in the discharge pipe, the air that the pump processes collects in these bridges and the pump will lose its self-priming and respective air handling capacity. The self-priming and air handling capacities are restricted by the static pressure on the discharge side of the pump. A MSP can create maximum 3 to 5 meter vacuum on the inlet of the pump, depending on the type. The speed, by which this vacuum is achieved, depends on the diameter and length of the suction line. The larger the volume of air that has to be handled, the longer it will take. Of this maximum achievable vacuum

the pressure that occurs during suction on the outlet of the pump (water column), has to be diminished. Consequently, a water column that stands on a one-way valve in the discharge pipe is very disadvantageous. Put the one-way valve on the inlet of the pump. A CRP, PRP or IRP pump can only handle air as long as the pressure on the outlet of the pump is smaller than 5 meter liquid column. Put the one-way valve also here on the inlet of the pump.

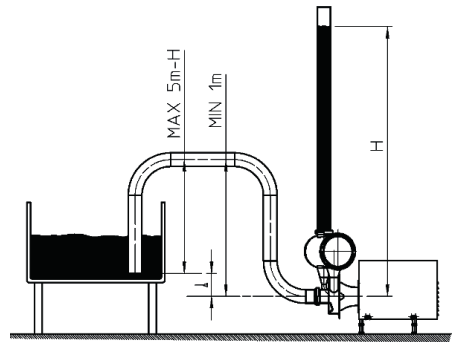

Since an air-handling pump has no water retaining vessel, special attention has to be paid to the pipe work in case the pump is not installed with a flooded suction. The pipe work has to make sure there remains enough water in the pump casing when the pump is switched off to give the pump its air-handling capacity on the next start-up.

For pumps lifting the liquid over a rim, a swan-neck is created. Important is that the inlet of the pump comes lower than the end of the pipe in the suction vessel.

ENG

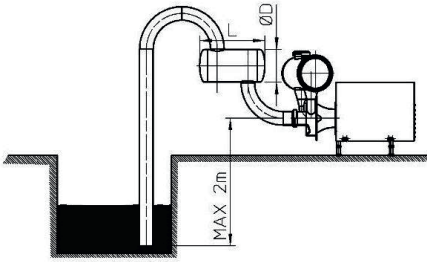

For pumps that have to lift the liquid from a well, installation of a suction vessel is needed. This suction vessel has to retain at least 4,5L liquid for pump types 32-125, 40-125, 40-160, 32-185 and 40-185 and 6L for all other types. A suction vessel can be made as indicated on the drawing beside. In order to retain 4,5L or 6L, the vessel has to be a lot larger. For retaining 4,5L the suction vessel can have a diameter D of 200mm and a length L of 350mm. For retaining 6L, the vessel should be at least 525mm long with a diameter of 200mm.

4.7. Pumps with quench

In a pump with quench the sealing faces of the mechanical seal are lubricated and/ or cooled by a liquid other than the pumped liquid. This lubricating liquid is supplied to and from the pump via the two connections in the quench chamber. There are four different types of quench (indicated by the fourth from last letter in the pump code on the nameplate of the pump. For a pump without quench this letter is "S", e.g. S33KEN):

- Q, or B: quench chamber sealed by a lip seal;
- D or C: pressure less double mechanical seal;
- P: double mechanical seal with pressurized barrier;
- I, J or K: flushed mechanical seal with forced circulation of the flushing liquid

In case of doubt about the type of quench on the pump, please contact PACKO.

The connection of the types **Q**, **B**, **D** & **C** is the same and can be done as follows in 2 ways:

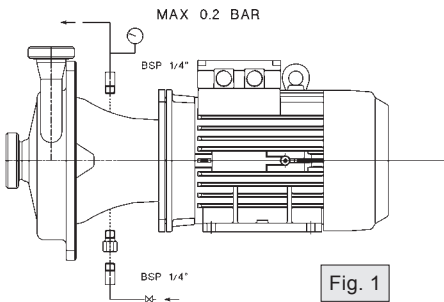

(Fig. 1) I.e., the throttle, supplied with the pump, is fitted to the bottom connection and connected to the water supply. The flow is set so that a small amount of water drips from the upper side (± 10 l/hour). It is preferable to fit a hose at the upper connection so that any leakage can be sent to drain. Never put a valve or restriction in the drain side of the quench liquid or pressure may build up in the quench chamber.

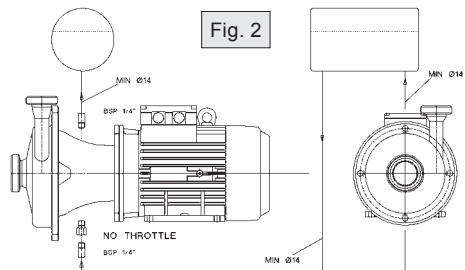

(Fig. 2) Alternatively, disregard the throttle and connect the quench chamber to a quench reservoir of at least 5 litres. To ensure sufficient circulation of the quench liquid its viscosity must be less than 100 centiPoise. The hoses must have an internal diameter of at least 14 millimeter and must be less than 2 metres long in total. The hoses must be arranged so that no air traps occur which will prevent circulation. The reservoir should be approximately 70 centimeter above the pump, both hoses must connect to the reservoir below the liquid level. The liquid level in the reservoir should be regularly checked and topped up accordingly and the hoses checked to ensure good circulation.

The temperature of the quench liquid must remain below 60 C, if it rises above this temperature a method of cooling must be arranged or a quench should be used. **The versions I and J** are connected in this second way (with reservoir).

In both arrangements the pressure in the quench chamber must never be greater than 0.2 bar!

For **type P or K** (fig. 3) (double pressurized seal) quench configuration the pressure in the quench chamber must always be at least 1 bar higher than the pressure on the inlet of the pump for pumps with open impeller and at least 4 bar higher than the pressure on the inlet of the pump for pumps with semi-open or closed impeller.

For multistage pumps (FMS and NMS) the pressure in the quench chamber is the same as the pressure on the outlet of the pump. The quench chamber is connected to the water supply at the bottom without the throttle. A valve should be fitted at the top of the outlet to regulate the flow rate to at least 10 litre per hour and a pressure gauge should be fitted between the outlet and the valve to check the pressure in the quench chamber. Special devices are widely available to regulate the flow and pressure in the quench chamber and PACKO strongly recommends that they are used.

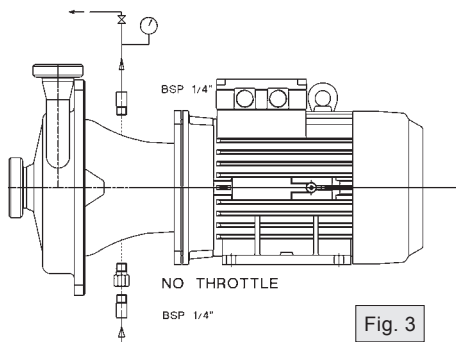

Fig. 3

4.8. Putting into operation

Pumps that are used for pumping foodstuffs have to be cleaned before the first use.

If the pump has been stored for a long time, first check by hand that the impeller turns freely. During starting up, the direction of rotation must be checked. For types FP, NP, CRP, IRP, 4100, 4600, KNM, 63, 66 and 68, this has to be carried out with an empty pump. For all other types the pump must first be filled with liquid. After filling with liquid, close the valve in the discharge pipe almost completely and open all the valves in the suction pipe completely. For AX pumps, start with all valves completely open.

For checking direction of rotation, start the pump and stop it immediately. Have a look to the motor fan (never remove the fan cover!) and notice the direction of rotation. The right direction is indicated with an arrow on the nameplate of the pump. When the motor is running in the wrong direction, switch off power, disconnect two phases in the terminal box of the motor and change them. Reconnect according procedure described in 4.4. Recheck direction of rotation and make sure the motor is running in the right direction.

For pumps on pedestal with oil lubrication, regulate the oil level to the middle of the gauge-glass. The oil used must have a viscosity according to ISO VG 68. The solid stainless steel plug of the

oil reservoir (installed during transport) must be removed and replaced by a plastic delivered plug with balance hole.

For VDK pumps with mechanical seal in oil bath, remove the solid plug on the oil bath (installed during transport) and replace it with the supplied dipstick. Check the oil level in the oil bath with

the dipstick. The minimum level is the bottom of the dipstick, the maximum level is the upper hole. The oil bath is Factory filled with "Black Point PL 15" manufactured by "Van Meeuwen". An alternative type of oil with a viscosity between 15 and 100cP can also be used. Do not mix two different types of oil.

4.9. Starting the pump

If the pump has not worked for a long time, first check by hand that the impeller turns freely.

- For types FP, ICP, NP, CRP, IRP, IFF, MFF, MCP, MFP, MWP, PRP, FMS, NMS, VDK, VPC, FPP, IPP and PHP: ensure the pump and suction pipe are filled completely with liquid and all valves in the suction pipe are completely open. Check that there are no leakages. **Never start a leaking pump or a pump in a leaking installation!** It is best to start the pump with the valve in the discharge pipe almost closed. After about 10 seconds (for pumps started with a frequency converter when the pump has reached the nominal speed) open the valve in the discharge pipe slowly until the desired flow is reached. As the valve is opened more, the current will increase. Check that the measured current is not higher than the nominal current on the nameplate of the motor.
- Types MSP: ensure there is enough liquid in the pump casing. If the pump has been previously used and was not drained via the drain plug, this is automatically the case. Before the first start up and every time the pump casing is

drained via the drain plug, fill the pump casing manually. The self-priming pump can prime the liquid in the suction pipe itself, only if the pressure on the outlet of the pump is zero. This means the valve in the discharge line should be opened and there must be no pressure in the discharge line. Check that there are no leakages. **Never start a leaking pump or a pump in a leaking installation!**

- Types AX: ensure the pump and suction pipe are filled completely with liquid and all valves in the suction pipe are completely open. Check that there are no leakages. **Never start a leaking pump or a pump in a leaking installation!** It is best to start the pump with the valve in the discharge pipe completely open. After about 10 seconds (for pumps started with a frequency converter when the pump has reached the nominal speed) close the valve in the discharge pipe slowly until the desired flow is reached. As the valve is closed more, the current will increase. Check that the measured current isn't higher than the nominal current on the nameplate of the motor.

5. Operation of the pump



The pump must never run without liquid.



In the event of cavitation, the pump must be stopped immediately.

5.1. Operation with closed valves, minimum flows

Operation with a closed valve in the discharge pipe is to be avoided. Due to internal friction

of the liquid in the pump, the temperature will rise quickly. The liquid inside the pump can

become so hot that it starts boiling with all the risks related to this. There always has to be a minimum flow of 1 m³/h per kW installed motor power. Except for FMS and NMS pumps where the minimum flow is 0.5 m³/h. Pumps that were built to handle large flows, but are operated at low flows, will, even when respecting the above mentioned minimum flows, operate unstable and therefore be subject to abnormal wear.

A pump must never operate with a closed valve in the suction pipe! In this case the pump will cavitate, resulting in abnormal wear and the possibility that the mechanical seal may be sucked out of its seat. Special attention is to be paid to automated installations. Make sure in the program that all valves in the suction pipe are opened before the pump is started.

In order to guarantee the lubrication of the mechanical seal in air-handling pumps (types CRP, IRP and PRP) and self-priming pumps (type MSP), they need to suck fluid in at least 20 % of the time (and thus no more than 80 % of the time air). A period in which only air is sucked in must never last longer than 5 minutes.

For pumps with a heating jacket on the pump casing or on the back plate, the suction valve and the valve in the discharge pipe must never be closed together as long as the heating is present; not even when the pump is switched off. By heating a closed quantity of liquid, extremely high pressures can be produced **and can lead to pump damage and serious burns.**

5.2. The phenomenon of water hammer

When a mass of liquid is stopped quickly or has a large acceleration, the pressure wave generated will have peaks that can reach tens of bars with a heavy load on the pump and pipes as a result. The longer the pipe works, the easier “water hammer” occurs.



“Water hammer” may be prevented by starting the pump with an almost closed valve in the discharge pipe and

by opening and closing valves slowly. In order to stop the pump, first close the valve in the discharge pipe slowly and then switch off the motor of the pump. Solenoid valves that open or close quickly should not be used. Any and all damage due to “water hammer” does not come into account for warranty.

Never try to stop a pump quickly by quick closure of a valve!

5.3. Operation of pumps with a frequency converter

Controlling the pump flow (automatic or not) by regulating the speed of the motor is the best way to save most energy. But please keep in mind the following before connecting the pump to a frequency converter. Standard PACKO pumps are designed to operate at 50 Hz or 60 Hz. When a pump is running faster, a high pressure can be produced in a small pump. Moreover, **the power consumption of the pump increases significantly when it is running quicker.** Motors powered by a frequency converter get hotter than motors connected to a harmonic sinus shaped power supply. Pump and motor will produce more noise when running faster. For reasons of

reliability, safety and comfort the maximum allowed speed of the pumps is limited by:

- the maximum pressure in the pipe word (see above 2.3);
- the motor power. When the pump runs faster, it needs more power;
- the maximum speed however, can never be higher than 3600 revolutions/minute.

When a motor is running very slowly, **its' own cooling could suffer. The minimum speed** is 15 Hz for pumps with a 2-, 4- or 6-pole motor and 25 Hz for pumps with an 8-pole motor.

When the speed range between this borders is not sufficient for your application, please discuss it with PACKO. In this case we can look for a special pump selection.

Motors to be connected to a frequency converter **must be ordered with built-in PTC thermal protection.**

Not only the frequency, but also the installation of the right voltage is very important. At 50 Hz and 60 Hz, the voltage on the nameplate of the motor must unconditionally be followed. At lower frequencies, the voltage must be lowered proportional.

5.4. Pumps that have to start and stop often

Pumps that have to start and stop often are subject to extra wear because certain parts are subject to repetitive shock loading. To start and stop a pump often must be avoided as much as possible.

Every time a motor starts, it draws a large electric current (starting current) that heats up the motor. **Pumps that have to start and stop more than 5 times an hour must be ordered with a motor with built-in PTC thermal protection.** When the pump has to start and stop often, this must be mentioned when ordering the pumps so that the motor can be selected accordingly.

5.5. Temporary decommissioning

After switching off the pump in the case of shutting down the installation, the suction and discharge valves should be closed. For pumps with a heating jacket on the pump casing or the back-plate, this heating also has to be turned off.

If the liquid remains in the installation, the valves should be locked so that they cannot be opened in error.

When there is a risk of frost, in the case of prolonged stoppages or when the liquid can coagulate inside the pump, the pump is to be emptied, cleaned and protected against frost.

5.6. Permanently decommissioning

Although Packo pumps are extremely durable, after many years of service, a moment comes when the pump will be permanently put out of service. Apart from the seals and smaller parts of the motor, the pump is completely built in metal. This metal can be recycled via the scrap trade. With smaller pumps, the motor fan and

fan cover are made of plastic, these can also be recycled. The seals, and electronic components of an optional frequency converter built on the motor, must be scraped and disposed of in accordance with the applicable local environmental legislation.

5.7. Directives in case of failure

Loud noises, severe vibrations or leakage indicate a malfunction or failure of the pump. Try to find the reason for failure. If there is a malfunction you do not recognize or you cannot repair

yourself, PACKO must be notified immediately. During the warranty period, you are not allowed to make repairs yourself without previous permission of PACKO.

5.8. Clearing a blockage

When the impeller cannot turn freely anymore, the pump must be switched off and the valves on the suction and the pressure side must be closed. Let the pump return to ambient temperature, empty, take out of the piping system and decontaminate if necessary. Disassemble the pump casing according the disassembly instructions in chapter 8. Remove the source of the blockage and reassemble the pump casing. Before reinstalling the pump back into the piping

system, check with your hand in the inlet of the pump, (for MSP types: on the ventilator of the motor) that the impeller is free to rotate in the pump housing. If this is not the case, the pump must be completely disassembled and checked for any damaged components, which must then be replaced by original Packo parts. When the cause of the blockage has been found and is prevented for the future, try again to assemble the pump according to the instructions in chapter 8.

6. Maintenance, spare parts and cleaning

6.1. Maintenance of the motor

Smaller motors are equipped with bearings greased for life and need no maintenance. From frame size 180 onwards (from 22 kW on 3000 rpm or 18.5 kW on 1500 rpm) motors are equipped with grease nipples for greasing the bearings. For some motor brand names, the frequency of greasing is indicated on the nameplate of the motor and must be followed. For motors where this is not mentioned, it is best to grease every 2000 operating hours when the ambient temperature is 25°C. If the ambient temperature is 40°C, the interval must be halved.

For pumps on a pedestal with an oil bath, check the level of the oil once a week. Change the oil after 3000 operating hours and at least once a year. **The grease in the pedestal bearings cannot be changed as they are sealed for life with a lifetime expectancy of about 20000 operating hours.** This value is only an indication. The best option is to replace the bearings when they seem to be worn (signs of wear are noise, vibrations,...).

6.2. Mechanical seal

Check the mechanical seal for leakage every week. When starting up a new pump, a few drops of liquid leakage per hour are possible because the seal surfaces need to be run in. This leakage should fully disappear after ten operating hours. In case of any damage to the mechanical seal, it should always be replaced, both the stationary part, rotating part and rubber parts. When opening the pump casing, the pump casing seal should also be replaced at the same time.

In order to replace the seals, clean the stainless steel pump parts.



For ATEX pumps with single mechanical seal, the seal has to be replaced at least after 3000 operating hours (see chapter 2.4)

For pumps with quench, check, and regulate if necessary, the flow of the quench fluid every week.

For pumps with a quench reservoir, check the level in the reservoir every week. Add liquid if necessary.

For VDK pumps with mechanical seal in an oil bath, check the level in the oil bath weekly and add liquid if necessary. Change the oil bath every 3000 operating hours and at least yearly.

6.3. Spare parts

For maintenance or repair use only original spare parts. Only then a reliable operation can be guaranteed and the certificates (machinery directive, ATEX, 1935/2004 EC, ...) delivered with the pump remain valid.

When ordering spare parts always state the type and serial number of the pump as indicated on the nameplate. It is advisable to keep a mechanical seal and O-rings in stock as a spare part, which should be stored in a cool and dry space without temperature fluctuations.

6.4. Cleaning

Pumps of the FP, PHP, CRP, PRP and FMS series are designed for easy CIP-cleanability (cleaning in place). Several tests have shown they are as cleanable as a tube with the same diameter of the pump inlet and a roughness $R_a = 0.8 \mu\text{m}$.

Pumps are used for several liquids. This makes it impossible to give a general valid CIP cleaning procedure. The following rule of thumb is applicable: the flow rate during the CIP process should be so high that the liquid velocity at the inlet of the pump is at least 1.5 m/s. The pump has to run during the CIP process and the drain valve (if present) has to be opened from time to time during the CIP process in order to clean this valve. The efficiency of the used cleaning procedure has to be checked during the validation of the installation in which the pump is incorporated. The following are some general recommendations.



**Cleansing media can cause burns!
Wear gloves and safety goggles.**

It is important to check that the internal seals of the pump are resistant to the cleaning media. If steam is used during one of the cleaning phases, the pump must not run at the same time. Check if the elastomers used are steam resistant.
In case of doubt, contact PACKO.

- **Product expelling phase** - With gas (N_2 in the pharmaceutical industry and CO_2 in the beverage industry) or liquid (water or solvent) the rest of the product can be removed out of the pump and piping. **If the system is blown empty with gas, the pump first must be switched off to prevent dry running.**

- **Pre-rinse** - The pre-rinsing is done with hot solvent or liquid ($45 - 55^\circ\text{C}$) in the pharmaceutical respective food industry. In the food industry, hot water prevents the dirt from hardening (fat), whereas higher temperatures lead to denaturizing of proteins, which are very difficult to remove. Pulsating the liquid flow (switching on and off the pump) can improve the cleaning. The pre-rinsing liquid is nearly always drained.

The pre-rinse can be undertaken with tap water and is very important because it can remove most of the dirt.

- **Cleaning with detergent and alkali** - This cleaning phase has to remove the organic or inorganic dirt based on the chemical or physical action of the detergent. The dirt has to be de-solved in the cleaning liquid. The return temperature is normally approximately 75°C and the chemical concentration between 0.5 and 3 m % (e.g. 100 l of water + 2.2 l NaOH of 33 %). Most of the dirt is loosened early in this phase. The cleaning can be done with tap water. Since the wash-step is based on the solution of residual dirt, the temperature of the water and detergent mixture is very important. If sequentially an alkaline and acid cleaning is used, normally there is a rinse in between.
- **Acid cleaning** - Acid cleaning is used for removal of inorganic dirt and normally only occasionally necessary. Often, inorganic acids (e.g. HNO_3) are used with a concentration between 0.5 and 3 m %. The temperature is less than 65°C . Afterwards a rinse is done with lukewarm water.

- **After rinse** - The reason for the after rinse is to remove all loosened dirt and detergent.
- **Disinfection** - The disinfection reduces the number of toxic micro-organisms to an acceptable level. However, the disinfection does not guarantee full sterility and is only sensible after a good cleaning.
- **Final rinse** - The final rinse has to be done with germ-free water with a total hardness below 5 °D (90 mg/l CaCO₃). The final rinse water is often used for pre rinse.

7. Problem solving

Failure	Possible cause	Solution
There is no suction	<ul style="list-style-type: none"> • Wrong direction of rotation • Valve in suction line or pressure line closed • Synthetic plugs are still in inlet or outlet • Insufficient de-aeration • For self-priming pumps: pressure on outlet of pump too high 	<ul style="list-style-type: none"> • Change two terminals • Open valves • Remove plugs • De-aerate better • Open all valves completely, decrease pressure in discharge vessel, make provisions so that no liquid column can be built up on the outlet of the pump, remove any non-return valve from the discharge pipe and, if necessary, install it directly on the suction of the pump.
Pump flow is too low	<ul style="list-style-type: none"> • There is no suction • Wrong direction of rotation • Valves are not opened enough • Impurities in the pipe work • Pump draws air • Air pockets in the suction line • Wrong motor connection 	<ul style="list-style-type: none"> • See above • Change two terminals • Open valves • Clean pipes • Stop leakages in suction line, raise level in suction tank • De-aerate • Reconnect in the right way
Pump produces low pressure	<ul style="list-style-type: none"> • Wrong direction of rotation • Cavitation • Motor is running too slow (frequency converter) • Wrong motor connection 	<ul style="list-style-type: none"> • Change two terminals • See below • Raise frequency • Reconnect in the right way
Cavitation (pump makes a cracking noise, pump hunts on/off line)	<ul style="list-style-type: none"> • Friction losses in suction line too high • Liquid temperature too high • Liquid level in suction tank too low 	<ul style="list-style-type: none"> • All valves in suction line must be completely open, enlarge diameters • Cool down liquid • Fill up tank or lower pump
Pump flow too high	<ul style="list-style-type: none"> • Friction losses too low 	<ul style="list-style-type: none"> • Close valve in discharge pipe
Pump blocks	<ul style="list-style-type: none"> • Pump wrongly assembled • Foreign body in the pump 	<ul style="list-style-type: none"> • Disassemble and assemble in the correct way • Clean

Failure	Possible cause	Solution
Motor uses too much current (Amperes)	<ul style="list-style-type: none"> • Wrong direction of rotation • Flow too high • Pump locks • Voltage too low 	<ul style="list-style-type: none"> • Change two terminals • See above • See above • Repair electrical failure
Motor overheats	<ul style="list-style-type: none"> • Motor uses too much current • Ambient temperature too high • Not enough cooling 	<ul style="list-style-type: none"> • See above • Cool dow • Do not let the motor run slower than on 25 Hz, improve air supply
Pump vibrates	<ul style="list-style-type: none"> • Cavitation • Pump draws air • Motor bearings worn 	<ul style="list-style-type: none"> • See above • Stop leakages in suction line, raise level in suction tank • Replace motor (bearings)
Pump leaks	<ul style="list-style-type: none"> • Mechanical seal broken • Pump casing seal broken 	<ul style="list-style-type: none"> • Replace mechanical seal • Replace pump casing seal
Pump makes abnormal noise	<ul style="list-style-type: none"> • Cavitation • Two touching parts or pumps blocks • Pump flow too high • Motor bearings worn 	<ul style="list-style-type: none"> • See above • See above • See above • Replace motor (bearings)

If the problem cannot be solved by means of the help above, or when you are not sure to have found the reason for the failure, please contact PACKO.

8. Assembly and disassembly

You will find the instructions for assembly and disassembly under <http://extranet.packo.com/en/packopumps>.

User name: assembly

Password: manual

